

Study of Pneumatic Speed Control System with Friction Force Compensation

Ye Yizhou¹, Wang Wenjin², Chen Xing¹

¹(College of Mechanical Engineering, Shanghai University of Engineering Science, Shanghai, China)

²(Shanghai Jiaoyun Auto Power Components Co., Ltd, Shanghai, China)

ABSTRACT: In this paper, the mathematical model of pneumatic speed control system was established and simulated through Matlab/Simulink. The conclusion that cylinder friction force must be compensated was provided after analyzing the simulation results. Some performance of the system could be improved in low cost through adding chatter signal to control signal to compensate cylinder friction force and combining with PID control.

Keywords - chatter signal, friction force compensation, mathematical model, speed control, simulation

I. INTRODUCTION

Pneumatic technology is a low cost automation. It has the characteristics about simple structure, clean, working reliably, easy to control and convenient maintenance. At present, pneumatic technology has been widely used in manufacture^[1]. Due to the factors of gas compressibility, cylinder friction force and the flow-pressure characteristics of control valve, precise pneumatic speed control is difficult to achieve. Among them, cylinder friction force is the most important factor^[2]. At present, almost all of the research on pneumatic speed control is utilizing control strategy to compensate cylinder friction force^[3]. These are too complex and high-cost to make them widely used. This paper shows a method to improve the performance of the system through adding chatter signal to compensate cylinder friction force and combining with PID control.

II. MATHEMATICAL MODEL OF THE PNEUMATIC SPEED CONTROL SYSTEM

This system adopts electric-pneumatic proportional valve, the model of system is shown in Fig.1.

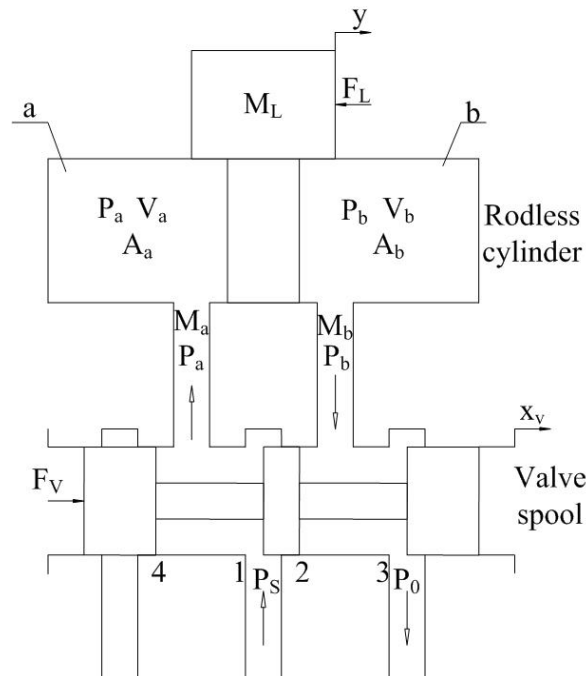

Fig.1 The Model Diagram of System

The gas is assumed as ideal gas, and its flow process is isentropic^[4]. The structure of valve spool is slide valve. All of valve spool and piston move to right. The gas flows into the chamber "a" of the cylinder and flows

out the chamber “b” of the cylinder. Pressures and volumes of the chamber “a” are P_a and V_a . Pressures and volumes of the chamber “b” are P_b and V_b . The effective areas of piston are A_a and A_b .

\dot{M}_a and \dot{M}_b are the mass flows that entering and leaving the two chambers of the cylinder.

$$\begin{aligned}
 \dot{M}_a &= \begin{cases} \frac{C_d W x_v p_s}{\sqrt{T_s}} \sqrt{\frac{2k}{R(k-1)}} \sqrt{\left(\frac{p_a}{p_s}\right)^{\frac{2}{k}} - \left(\frac{p_a}{p_s}\right)^{\frac{k+1}{k}}} & \left(\frac{p_a}{p_s} \geq c_0\right) \\ \frac{C_d W x_v p_s}{\sqrt{T_s}} \left(\frac{2}{k+1}\right)^{\frac{1}{k-1}} \sqrt{\frac{2k}{R(k+1)}} & \left(\frac{p_a}{p_s} < c_0\right) \end{cases} \\
 \dot{M}_b &= \begin{cases} \frac{C_d W x_v p_b}{\sqrt{T_b}} \sqrt{\frac{2k}{R(k-1)}} \sqrt{\left(\frac{p_o}{p_b}\right)^{\frac{2}{k}} - \left(\frac{p_o}{p_b}\right)^{\frac{k+1}{k}}} & \left(\frac{p_o}{p_b} \geq c_0\right) \\ \frac{C_d W x_v p_b}{\sqrt{T_b}} \left(\frac{2}{k+1}\right)^{\frac{1}{k-1}} \sqrt{\frac{2k}{R(k+1)}} & \left(\frac{p_o}{p_b} < c_0\right) \end{cases}
 \end{aligned}
 \tag{1}$$

In equation (1) and equation (2), C_d is discharge coefficient of valve orifice, W is the area gradient of slide valve, x_v is spool travel, T_s is the temperature of air supply, T_a and T_b are the temperatures of the two chambers of cylinder, R is gas constant, k is the ratio of specific heat at constant pressure to specific heat at constant volume.

According to Taylor formula, equation (1) and equation (2) can be linearized. Then, equation (3) and equation (4) can be obtained.

$$\Delta \dot{M}_a = \dot{M}_a = K_{ma} \Delta x_v - K_{ca} \Delta p_a = K_{ma} x_v - K_{ca} p_a \tag{3}$$

$$\Delta \dot{M}_b = \dot{M}_b = K_{mb} \Delta x_v - K_{cb} \Delta p_b = K_{mb} x_v - K_{cb} p_b \tag{4}$$

In equation (3) and equation (4), $K_{ma} = \frac{\partial \dot{M}_a}{\partial x_v}$, $K_{mb} = \frac{\partial \dot{M}_b}{\partial x_v}$, K_{ma} and K_{mb} are the mass flow gain of

electric-pneumatic proportional valve, $K_{ca} = -\frac{\partial \dot{M}_a}{\partial p_a}$, $K_{cb} = -\frac{\partial \dot{M}_b}{\partial p_b}$, K_{ca} and K_{cb} are the mass flow-pressure coefficient of electric-pneumatic proportional valve.

According to law of conservation of mass, equation (5) can be obtained.

$$\sum \dot{M}_{in} - \dot{M}_{out} = \frac{dM}{dt} = \frac{d(\rho V)}{dt} = \rho \frac{dV}{dt} + V \frac{d\rho}{dt} \tag{5}$$

According to state equation of ideal gas, equation (6) can be obtained.

$$\frac{dM}{dt} = \frac{1}{RT} \left(p \frac{dV}{dt} + V \frac{dp}{dt} - \frac{pV}{T} \frac{dT}{dt} \right) \tag{6}$$

According to $\frac{dT}{dt} = \frac{k-1}{k} \frac{T}{p} \frac{dp}{dt}$ and equation (6), equation (7) and equation (8) can be obtained.

$$\dot{M}_a = \frac{dM_a}{dt} = \frac{1}{RT_a k} \left(k p_a \frac{dV_a}{dt} + V_a \frac{dp_a}{dt} \right) \tag{7}$$

$$\dot{M}_b = \frac{dM_b}{dt} = \frac{1}{RT_b k} \left(kp_b \frac{dV_b}{dt} + V_b \frac{dp_b}{dt} \right) \quad (8)$$

It is generally believed that the performance of pneumatic system is worst when the initial position of piston is middle of cylinder stroke^[5].

This paper assumes that $\dot{M}_a = 0 + \Delta \dot{M}_a$, $V_a = V_{ai} + A_a \Delta y_a$, $\dot{M}_b = 0 - \Delta \dot{M}_b$, $V_b = V_{bi} - A_b \Delta y$, $A_a p_{ai} = A_b p_{bi}$, $n = \frac{A_b}{A_a}$, $p_{bi} = \frac{1}{n} p_{ai}$, $V_a = V_{0a}$, $V_b = V_{0b}$, $m = \frac{V_{0b}}{V_{0a}}$, $T_{ai} = T_{bi} = T_s$. According to equation (7) and equation (8), equation (9) and equation (10) can be obtained.

$$m_a = \frac{1}{RT_s k} \left(kp_{ai} A_a \frac{dy}{dt} + V_{0a} \frac{dp_a}{dt} \right) \quad (9)$$

$$-m_b = \frac{1}{RT_s k} \left(-kp_{bi} A_b \frac{dy}{dt} + V_{0b} \frac{dp_b}{dt} \right) = \frac{1}{RT_s k} \left(-k \frac{1}{n} p_{ai} n A_a \frac{dy}{dt} + m V_{0a} \frac{dp_b}{dt} \right) \quad (10)$$

The force balance equation of cylinder is equation (11).

$$p_a A_a - p_b A_b = M_L \frac{d^2 y}{dt^2} + k_v \frac{dy}{dt} + K_L y + F_L = A_a (p_a - p_b n) \quad (11)$$

In equation (11), M_L is the total mass of piston and load, k_v is viscous damping coefficient, K_L is load spring stiffness, $K_L = 0$, F_L is disturbing force, $F_L(s) = P_b(s) = 0$.

Through equation (3), equation (4), equation (9) and equation (10), equation (12) can be obtained.

$$\left(K_{ma} + \frac{n}{m} K_{mb} \right) x_v - K_{ca} p_{La} - \left(\frac{n}{m} K_{cb} + n K_{ca} \right) p_b = \frac{1}{RT_s k} \left[V_{0a} \frac{dp_{La}}{dt} + \left(1 + \frac{n}{m} \right) kp_{ai} A_a \frac{dy}{dt} \right] \quad (12)$$

In equation (12), $p_{La} = p_a - np_b$. Through Laplace transform, equation (12) and equation (11) can be respectively transformed into equation (13) and equation (14).

$$\left(K_{ca} + \frac{V_{0a} s}{RT_s k} \right) P_{La}(s) = \left(K_{ma} + \frac{n}{m} K_{mb} \right) X_v(s) - \left(\frac{n}{m} K_{cb} + n K_{ca} \right) P_b(s) - \frac{1}{RT_s} \left(1 + \frac{n}{m} \right) p_{ai} A_a s Y(s) \quad (13)$$

$$A_a P_{La}(s) = (M_L s^2 + k_v s + K_L) Y(s) + F_L(s) \quad (14)$$

Through equation (13) and equation (14), the block diagram of system can be obtained, it is shown in Fig.2.

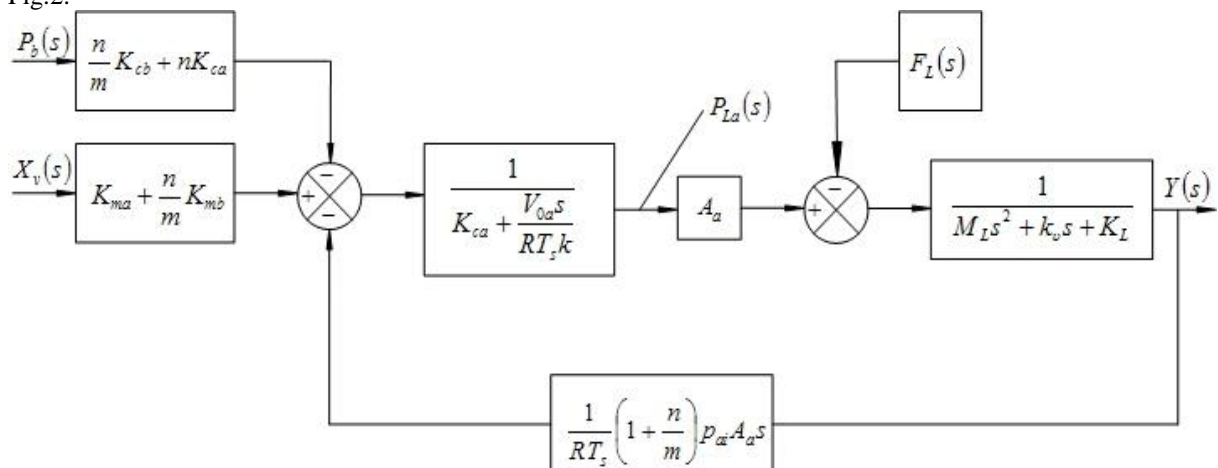

Fig.2 The Block Diagram of System

From Fig.2, the transfer function that spool travel as input and piston displacement as output can be obtained. $X_v(s)$ is spool travel, $Y(s)$ is piston displacement. The transfer function is equation (15).

$$\frac{Y(s)}{X_v(s)} = \frac{b_0}{s \left(\frac{s^2}{\omega_0^2} + \frac{2\xi_0}{\omega_0} s + 1 \right)} \tag{15}$$

In equation (15), $b_0 = \frac{(K_{ma} + \frac{n}{m} K_{mb})RT_s}{A_a p_{ai} (1 + \frac{n}{m})}$, $\omega_0 = \sqrt{\frac{(1 + \frac{n}{m})k p_{ai} A_a^2}{M_L V_{0a}}}$, ω_0 is the natural frequency of

system, $\xi_0 = \frac{K_{ca}RT_s}{2A_a p_{ai}} \sqrt{\frac{k p_{ai} M_L}{(1 + \frac{n}{m})V_{0a}}} + \frac{k_v}{2A_a} \sqrt{\frac{V_{0a}}{(1 + \frac{n}{m})k p_{ai} M_L}}$, ξ_0 is the damping ratio of system.

$U_w(s)$ is the control voltage of electric-pneumatic proportional valve. v is the speed of piston. $v = \dot{y}$, $V(s) = sY(s)$, K_d is the gain of electric-pneumatic proportional valve. Through known parameters, equation (16) can be obtained.

$$\frac{V(s)}{U_w(s)} = s \frac{Y(s)}{X_v(s)} \frac{X_v(s)}{U_w(s)} = s \frac{b_0}{s \left(\frac{s^2}{\omega_0^2} + \frac{2\xi_0}{\omega_0} s + 1 \right)} K_d = \frac{b_0 K_d}{\left(\frac{s^2}{\omega_0^2} + \frac{2\xi_0}{\omega_0} s + 1 \right)} = \frac{1270.12}{s^2 + 17.5s + 86.34} \tag{16}$$

III. SYSTEM SIMULATION AND ANALYSIS

This paper simulates system by Matlab/Simulink, input signal is unit step signal. Fig.3 shows the simulation model diagram of system. Fig.4 shows the simulation result. Fig.5 shows the bode diagram of system.

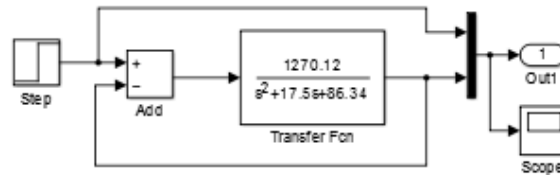

Fig.3 The Simulation Model Diagram of System

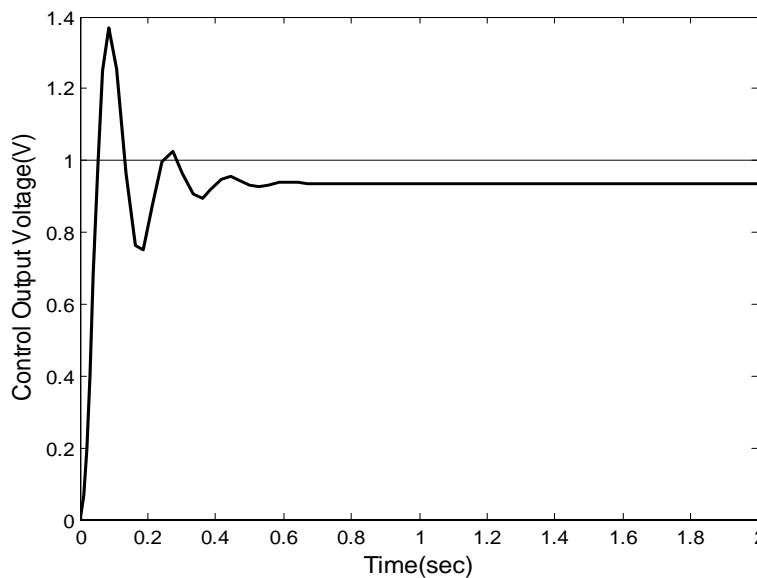

Fig.4 The Simulation Result

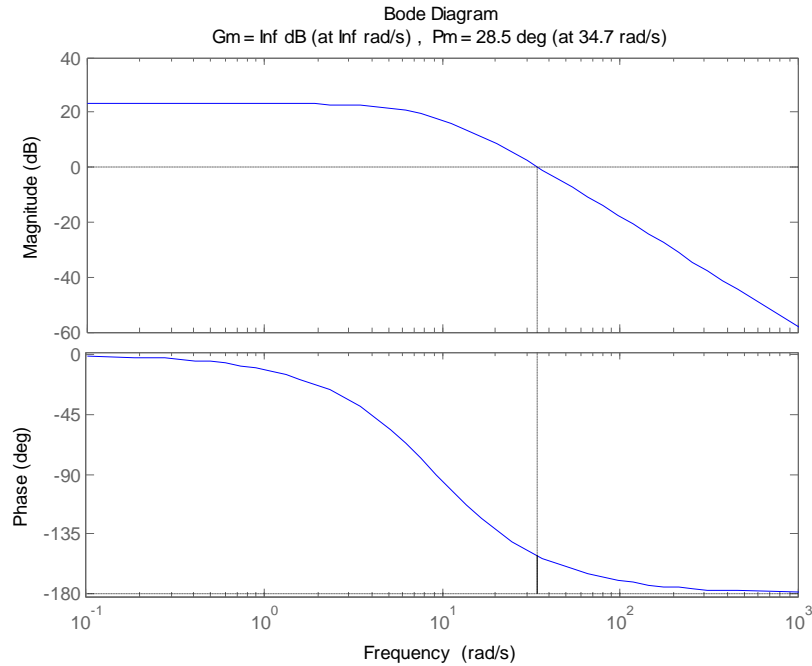

Fig.5 Bode Diagram

From Fig.4, it can be known that the system transient response is not perfect. The overshoot of system is 36.98%, it is excessive. The steady-state error of system is 6.3%. The time that system reaches stable state is 0.777s.

From Fig.5, it can be known that the stability margin of system is $\infty > 1$. The phase stability margin of system is $28.5^\circ > 0$. It is easy to know that the system is stable in open-loop condition, so the system is stable.

The overshoot of system is mainly caused by the friction force mutation of cylinder^[5]. Especially, when system is operating at low speed, the friction force mutation of cylinder will cause the crawling phenomenon of cylinder^[6-7]. This crawling phenomenon will cause speed fluctuation and reduce the performance of system^[8].

The friction force mutation of cylinder is caused by the difference between the coefficient of static friction and the coefficient of kinetic friction. If this difference had been reduced or eliminated, the generation of this crawling phenomenon would be reduced or disappeared.

Through adding chatter signal to control signal, some or all of the static friction force of cylinder will become the kinetic friction force of cylinder^[9]. Then, the difference between the coefficient of static friction and the coefficient of kinetic friction will be reduced or eliminated, so the generation of the crawling phenomenon of cylinder will be reduced or disappeared.

The chatter signal is sine signal with high frequency and low amplitude, it is $A\sin(\omega t)$ and $\omega > \omega_0\sqrt{1+2\xi_0^2}$.

In this paper, there are two different chatter signals that be respectively added to control signal. These two control strategies are respectively called “1#” and “2#”. Fig.5 shows the simulation model diagram of system with cylinder friction force compensation. Fig.6 shows the simulation results of system with cylinder friction force compensation. From Fig.6, simulation results table can be obtained, it is Table.1. In Table.1, T_s is the time that system reaches stable state.

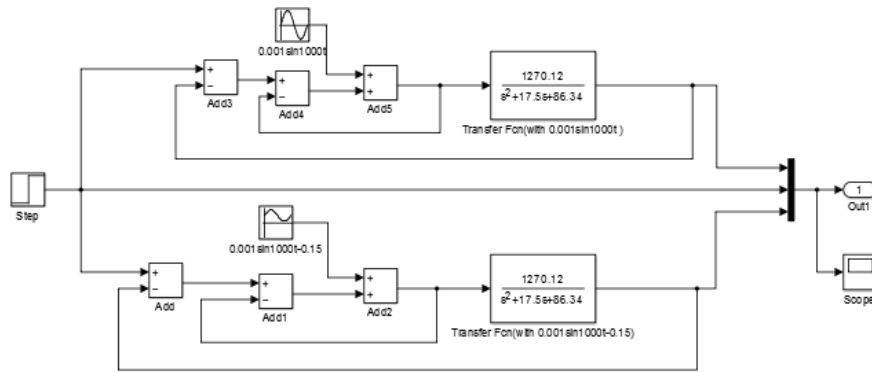

Fig.5 The Simulation Model Diagram of System with Cylinder Friction Force Compensation

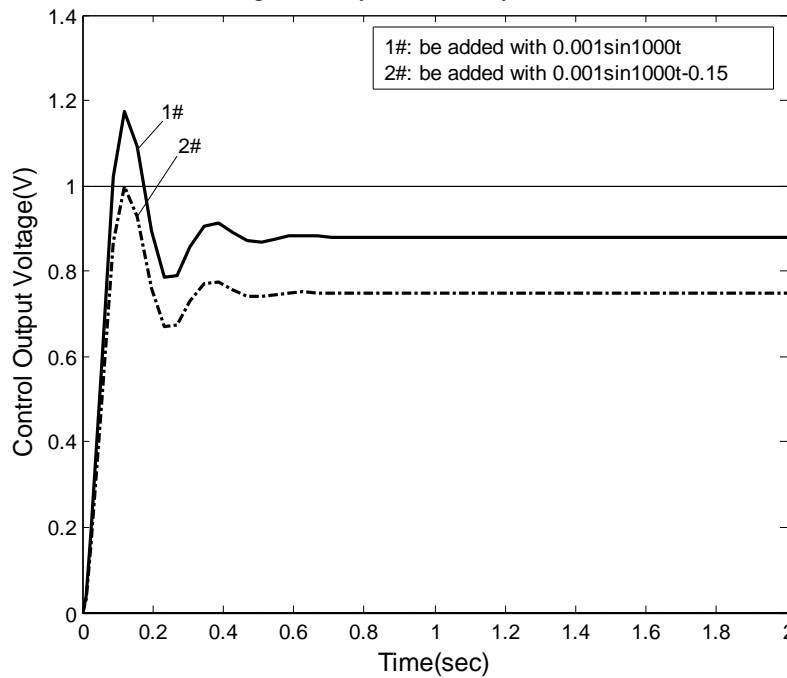

Fig.6 The Simulation Results of System with Cylinder Friction Force Compensation

Table.1 The Simulation Results of System

Name of Control Strategy	1#	2#
Chatter Signal	$0.001\sin(1000t)$	$0.001\sin(1000t) - 0.15$
The Overshoot of System	17.78% (< 36.98%)	≈ 0 (< 36.98%)
The Steady-State Error of System	11.9% (> 6.3%)	25.175% (> 6.3%)
Ts	0.771s (< 0.777s)	0.771s (< 0.777s)
The Stability of System	Stable	Stable

From Table.1, it can be known that after adding chatter signal to control signal, the adverse effect of the friction force mutation of cylinder will be eliminated or partial eliminated. This can improve the speed of system response, but the steady-state error of system will be increased. So, the system needs to combine with other control strategy to eliminate the steady-state error of system.

This paper adopts PID control to eliminate the steady-state error of system. According to the situation of system, people only need to adjust three parameters of PID control. These three parameters are Proportion (P), Integral (I) and Differential (D), respectively. PID control compares with other control strategies, it is simpler and more used widely. PID control has the characteristics about simple algorithm, good robustness, good reliability. PID control has occupied more than 95% of the field of industrial control^[10]. At present, there are a lot of mature PID hardware controllers on the market. They can be used in practice at low cost.

Fig.7 shows the simulation model diagram of system by PID control. Fig.8 shows the simulation results of system by PID control. From Fig.8, final simulation results table can be obtained, it is Table.2. In Table.2, Ts is the time that system reaches stable state.

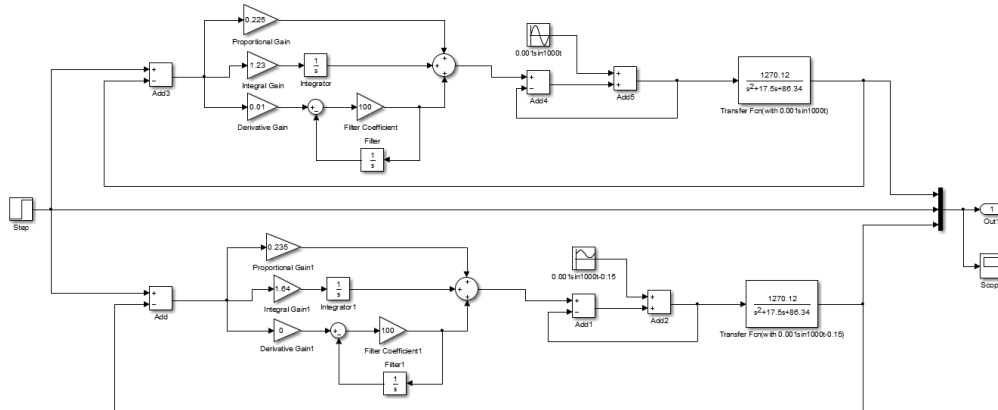

Fig.7 The Simulation Model Diagram of System by PID Control

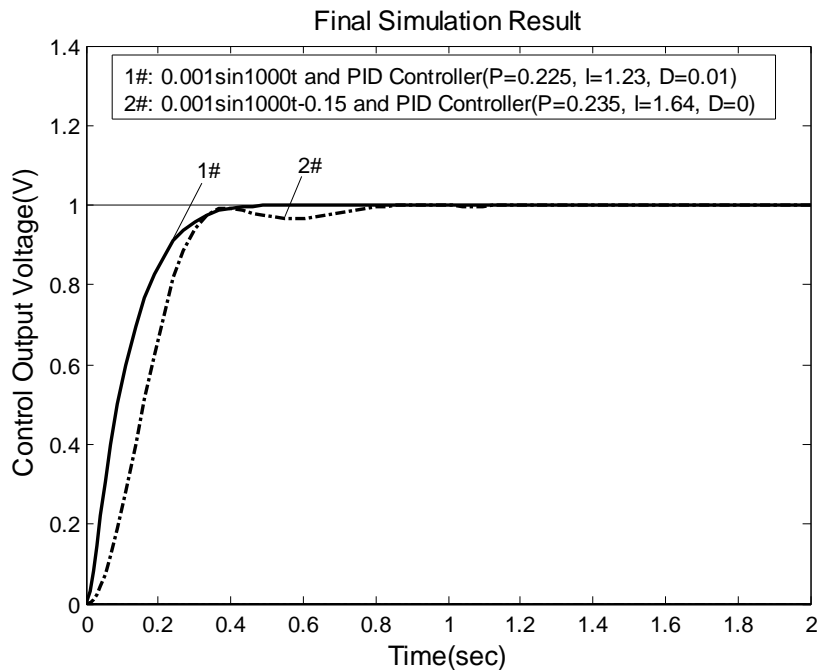

Fig.8 The Simulation Results of System by PID Control

Table.2 The Final Simulation Results of System

Name of Control Strategy	1#	2#
Chatter Signal	0.001sin(1000t)	0.001sin(1000t) – 0.15
The three parameters of PID Control	P=0.225, I=1.23, D=0.01	P=0.235, I=1.64, D=0
The Overshoot of System	0(<36.98%)	0(<36.98%)
The Steady-State Error of System	0(<6.3%)	0(<6.3%)
Ts	0.524s(<0.771<0.777s)	0.813s(>0.777s)
The Stability of System	Stable	Stable

From Table.2, it can be known that after adding PID controller to the system, the adverse effect of the friction force mutation of cylinder will be eliminated. From Fig.8, it can be known that the process of the system by control strategy “1#” is more smoothly. Through comparing these two simulation results in Table.2, it can be known that the performance of the system by control strategy “1#” is better.

IV. CONCLUSION

Achieving precise control of pneumatic speed can further expand the scope of application of pneumatic technology. But at present, the research documents of pneumatic speed control are relatively less. This paper belongs to preliminary exploration about pneumatic speed control. Cylinder friction force is the most important factor that makes pneumatic system difficult to achieve precise speed control. The friction force mutation of cylinder mainly refers to the transition between the kinetic friction force of cylinder with the static friction force of cylinder, it can cause speed fluctuation. Especially in the state of low speed, this mutation can cause the crawling phenomenon of cylinder. That will affect the precision of speed control and reduce the performance of system. Through adding chatter signal to control signal, part of the friction force mutation of cylinder can be eliminated, this can compensate part of the adverse effects of cylinder friction force. Then through combining with PID control, the steady-state error of system and the rest of the adverse effects of cylinder friction force will be eliminated. This control strategy can effectively restrain pneumatic speed fluctuation and the generation of the crawling phenomenon of cylinder. Be compared with other control strategies, this control strategy can achieve similar control effect at low cost, and it is relatively simpler. So, this control strategy has good practical value.

REFERENCES

- [1] Wang Jiwei, Zhang Hongjia, Huang Yi, Hydraulic and Pneumatic Transmission (Beijing, China Machine Press, 2013).
- [2] Jiang Zhouyong, Li Zuoli, Cylinder Friction Force Compensation and Simulation Research Base on Matlab, Coal Engineering, 2007(1).
- [3] Qiu Zhicheng, Wang Bin, Direct Adaptive Fuzzy Control of a Translating Piezoelectric Flexible Manipulator Driven by a Pneumatic Rodless Cylinder, Mechanical Systems and Signal Processing, 2013(36), 290~316.
- [4] Wu Zhengsun., Pneumatic Transmission and Control (Harbin, Harbin Institute of Technology Press, 2010).
- [5] SC Fok, Position Control and Repeatability of a Pneumatic Rodless Cylinder System for Continuous Positioning, Robotics and Computer Integrated Manufacturing, 1999(15), 365~371.
- [6] Ciliz MK, Omizuka M, Neural Network Based Friction Compensation in Motion Control, Electronics Letters, 40(12), 2004, 752-753.
- [7] Bender FA, Ampaert V, Modeling of Dry Sliding Friction Dynamics: From Heuristic Model to Physically Motivated Models and Back, Chaos, 14, 2004, 446-460.
- [8] Xie Zugang, Study of the Friction Force of the Cylinder in Low Speed, Zhejiang University, Zhejiang, 2003.
- [9] Kong Xiangzhen, Liu Yanjun, Chatter Compensation and Simulation for the Pneumatic Cylinder with Friction, Lubrication Engineering, 8(8), 2006.
- [10] Hagglund T, A Friction Compensator for Pneumatic Control Valve, Journal of Process Control, 8(12), 2002, 97~99.